



FARR APC
Air Pollution Control

Case Study

Torit Loses Seat at Plasma Table, Gold Series Cleans Up

Product: Gold Series
Size: GS24 Designed for 10,000 CFM
Application: Smoke from Plasma Cutting Table
Customer: Chatham Steel - Columbia, SC
Representative: Process Resources, Inc.



Challenge

Farley Laserlab manufactures plasma and laser tables. They are located in Rockford, Illinois and have corporate offices in Melbourne, Australia. They contacted Farr APC due to a problem they were having with a Torit collector on a new table. The table and collector were sold and installed at Chatham Steel in Columbia, South Carolina. The Torit collector (left) was undersized for the required airflow for the table and was also having pressure drop problems.

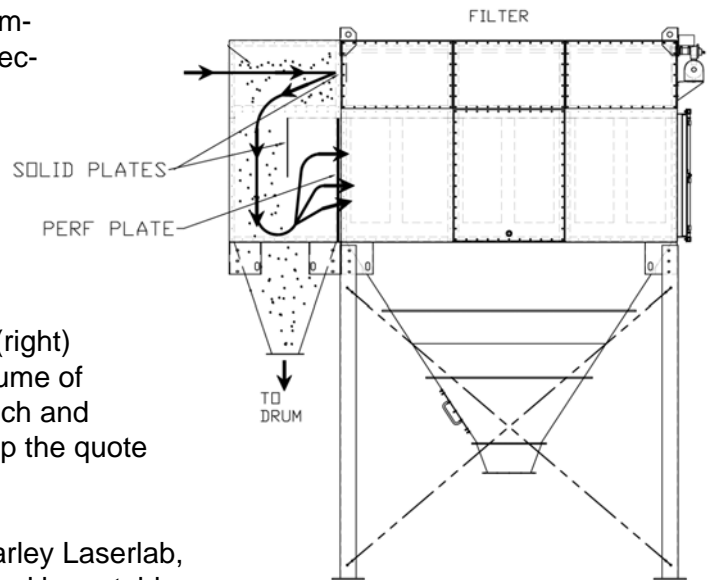

Solution

Farr APC rep John Dietrich of Process Resources quoted a Gold Series GS24 with an integral drop out box (right) based on an air-to-cloth ratio of 1:1 and an applied air volume of 150 cfm per square foot of table surface area. John Dietrich and Farr APC regional sales manager John Dauber followed up the quote with a visit and a GS demo trailer to Farley (below).

John Johnson, Vice President and General Manager of Farley Laserlab, was somewhat skeptical of Farr experience with plasma and laser tables.



He stated, "Everyone uses Torit. Who is Farr?" We reviewed the Farr Plasma and Laser Market Focus sheet, case studies and validated the airflow needed for the table.

John was then convinced that Farr was very knowledgeable about this type of application, but still was not sold. We then went outside and gave him a demonstration of the GS4 collector on our trailer. Mr. Johnson was very impressed with our collector. After seeing the unit John said, "We need to start working with you guys, not Torit!" *(continued)*

Farr APC Case Study (con't)



Farr Gold Series GS24 installed at Chatham Steel on a plasma cutting table application.

Al Hutto with Chatham Steel was in North Carolina the same day looking at a larger, used Torit to replace the undersized Torit. John Dauber suggested that Tomm Frungillo, Farr APC regional sales manager, bring his GS trailer so Al could look at it. John Johnson called Al and he agreed to see the trailer. Tomm was just getting back from a long trip, but jumped at the chance to show off the GS demo. When Al Hutto saw the GS on a trailer he was also very impressed and agreed that the Gold Series was what Chatham Steel wanted.

Farley issued the purchase order even though we were significantly higher in price than the used Torit. The Farr APC plant in Jonesboro, Arkansas came through as usual and the collector shipped in less than a week.

The collector was installed and started up a few weeks later. It captured all of the smoke, even on the worst case cutting. The collector is maintaining between 1" to 2" of pressure drop and should see excellent cartridge life.

Chatham steel has an older plasma table with a Torit collector that is failing to capture the smoke. Chatham Steel is so impressed with the Gold Series that they have asked for a quote to replace that Torit unit as well.

For further information regarding this application, contact Farr rep John Dietrich of Process Resources, Inc. at 630-810-9300 or Farr APC regional manager John Dauber at 402-791-5333.



Before Farr Gold Series collector was installed - smoke from plasma cutting operation filled the facility.



After Farr Gold Series collector was installed - plasma smoke is well controlled, maintaining clean operating conditions and ensuring worker safety.